



# VX-2000 Series

Flexible public address and voice alarm system



**sound** without compromise

[www.toa.eu](http://www.toa.eu)

# RELIABLE & FLEXIBLE



EN 54-16 certified  
 Certificate No: 1134-CPR-110  
 Fulfills the VDE 0833-4, EN 60849 / VDE 0828  
 EN 54-4 certified  
 Certificate No: 1134-CPR-083



## A SYSTEM CONQUER THE WORLD

Continuously TOA brings the knowledge gained from years of experience in the development and production of sound and security systems, which is reflected in the high reliability of many installations worldwide.

Our VX-2000 Series – specifically developed to meet the high German standards in a voice alarm system – is now successfully used far beyond the German borders.

- Integrated system for public address and voice evacuation
- Fulfills all requirements of the applicable standards
- System status can be confirmed on the central indication panel and remote microphones
- Optional linkable central control units possible
- OPC Client for connection to external systems

The flexible system fulfills all requirements from simple to highly complex installations and ensures not only professional sound with superb audio quality but also a safe environment for the public.

Thus, the VX-2000 system can be used wherever a permanently installed sound system with voice evacuation is needed, such as in hospitals, train stations, hotels, schools and shopping centers.

- Simultaneous 2-channel recorded message broadcasts
- Continuous speaker line monitoring without interruption of BGM or paging announcements
- Convenient multi-language software
- Event memory for efficient system maintenance
- Remote maintenance with optional accessories

## CUSTOMIZED AND COST-EFFECTIVE

The digital VX-2000 system is composed of a System Manager, Surveillance Frame, Power Amplifiers, Power Supply, Emergency Power Supply, Fireman's Microphone and user-specified number of Remote Microphones.

It's fully modular design allows maximum flexibility, so that systems can be customized to suit the needs from the outset and are also easy to expand. This makes the VX-2000 series a powerful and cost-effective platform for almost any application.

The system manager has 8 slots for input modules to fit the various sound sources. It manages up to 8 remote microphones – incl. 4 emergency remote microphones, different chime tones are also integrated. In addition, 2 memory modules for automatic voice announcements can be used.

Up to 80 speaker lines in A/B-wiring can be controlled. Furthermore, a remote access is possible, e.g. via telephone modem. For an easy remote maintenance all software functions are supported.

## APPLICATION EXAMPLES



Department stores



Hotels

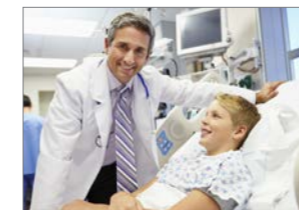

Hospitals



Exhibitions



Schools



Retail- and supermarkets



Train stations

# SAFE & VERSATILE



## HIGH RELIABILITY

For the case of failure there is a CPU cut-off switch right on the fireman's microphone which ensures the all-call function is still available. Of course, it is also equipped with standard-compliant self-test features including acoustic monitoring of the microphone capsule.

## NON-INTERRUPTIVE SURVEILLANCE

To ensure continued safety the VX-2000 features different failure detection measures that constantly check components and speaker lines for any faults or abnormalities without interruption of BGM or paging announcements.

## NETWORK-COMPATIBLE DESIGN

The optional NX-100 network adapter enables a decentralized structure of the system. It uses existing network connections without expensive rewiring.

## INDIVIDUAL ASSIGNMENT

The remote microphone keys are freely programmable for different functions and also come with a definite pressure point to obtain feedback on operation.

## READABLE SYSTEM STATUS

The system status is displayed on each remote microphone and optionally on an indication panel at the system manager.

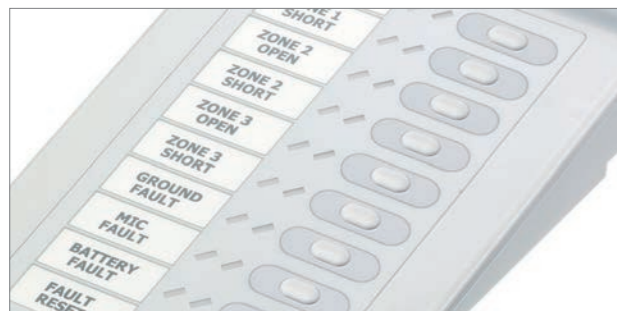

## AUTOMATIC DUAL BROADCASTING

Simultaneous dual broadcasting is possible by using two voice announcement cards to allow different messages to be available at the same time such as alert and evacuation messages. Thus it ensures an orderly and rapid evacuation.

## VERSATILE SOFTWARE

The software provided freely with the VX-2000 for easy system configuring and parameter setting has multilingual options for convenient use by personnel in any location.

## DIGITAL AMPLIFIERS AND OPTIMIZED POWER SUPPLY

The expansion of the product line to digital Power Amplifiers and a digital Power Supply Manager offers significant advantages:

- significant reduction of cabinet size
- reduction in the weight
- less powerloss and heat loss
- short installation time
- space-saving, cheaper transport

## CONVENIENT SUPPLEMENTARY TOOL

For designing the Power Supply a supplementary tool according to BS 5839-8 is available free of charge.



Digital Class-D Power Amplifier, EN-54-16 certified

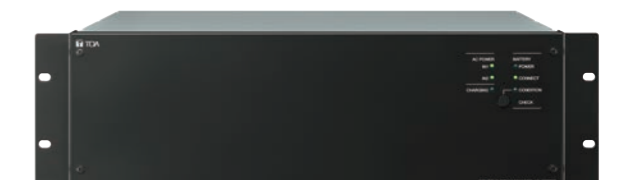
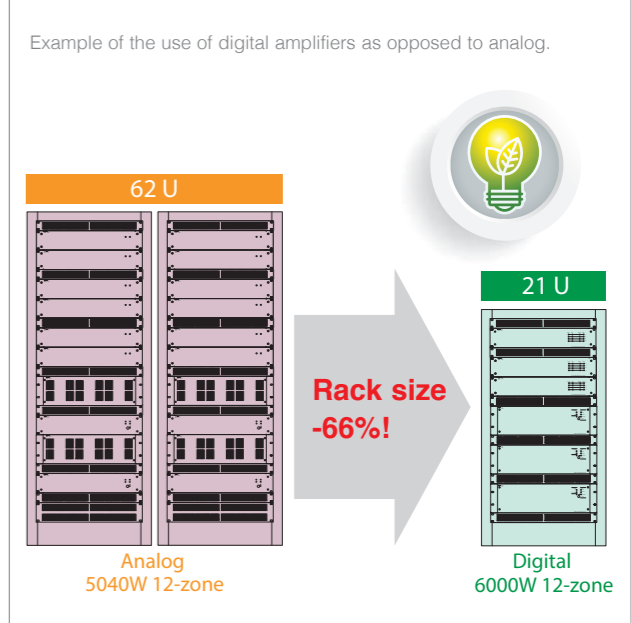
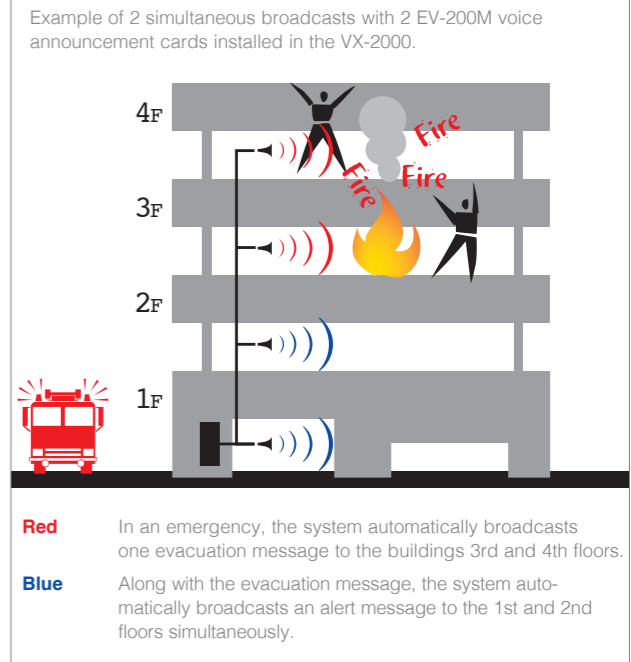

Digital Power Supply Manager, EN-54-4 certified

# SYSTEM CONFIGURATION

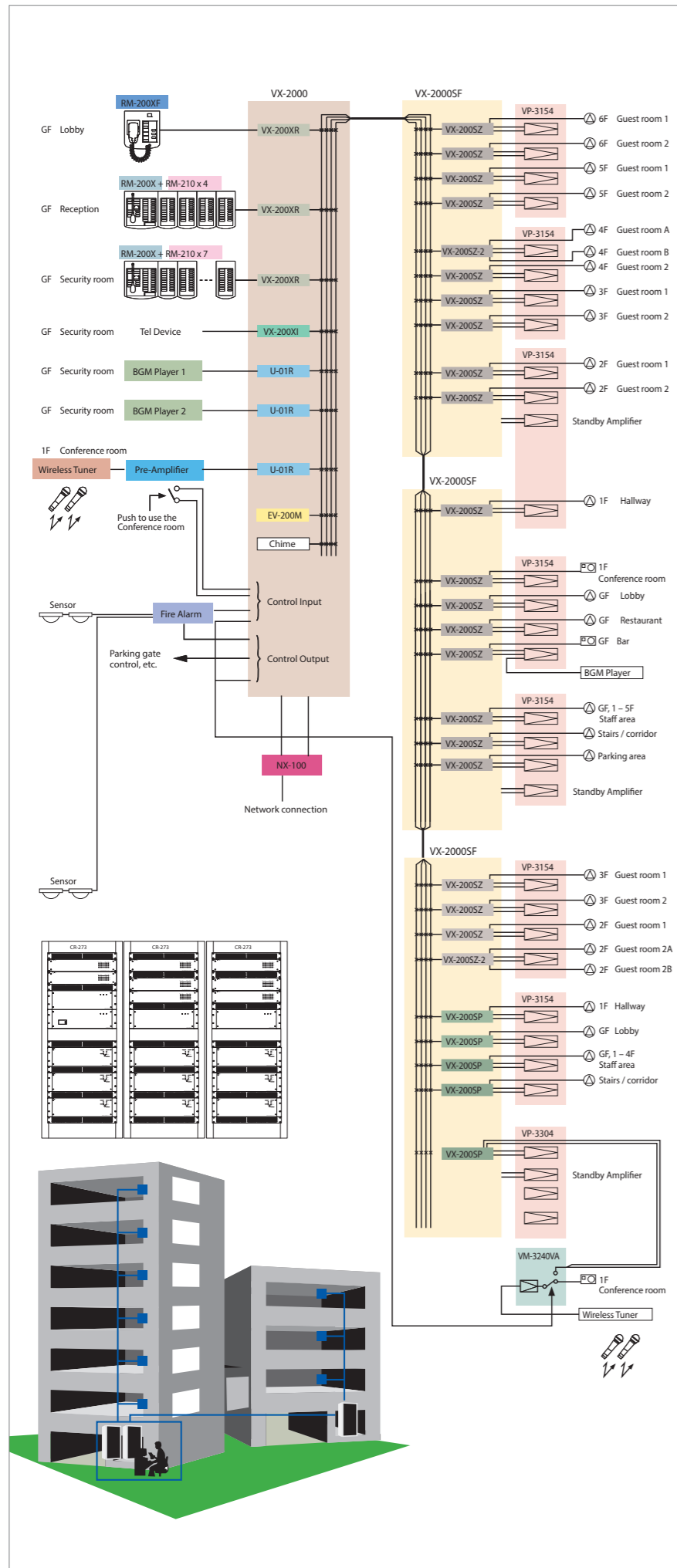

EN 54  
16

## VX-2000 System Manager

An input matrix unit that assigns input signals to 4 audio buses, and functions as the VX-2000 system's main controller. A total of up to 8 units of the VX-200XI, VX-200XR, and other input modules can be mounted in a System Manager. The VX-2000 can control audio signal routing, priorities, and peripheral equipment, while system configuration settings are performed by PC setting software. Up to 2,000 system events and failures can also be recorded, and the log can be viewed from a PC.



EN 54  
16

## VX-2000SF Surveillance Frame

The VX-2000SF Surveillance Frame is the output matrix section of the VX-2000 system that assigns audio signals to individual zones from 4 audio buses. It can be extended up to 8 units. A total of 10 units of output modules and control modules can be installed per VX-2000SF.

## RM-200XF Fireman's Microphone

A dedicated microphone for the VX-2000 system, the RM-200XF is designed to be exclusively used for emergency broadcast, however it can be used for general purpose broadcast applications as well.



EN 54  
16

## RM-200X Remote Microphone

The RM-200X is a dedicated unit for the VX-2000 system, permits emergency broadcast as well as general purpose broadcast. The PC-programmable system software permits desired functions to be assigned to individual function keys.



EN 54  
16

## RM-210 Key Extension Unit

Extension unit for increasing the number of function keys of TOA's RM-200X and RM-200XF Remote Microphones.



EN 54  
16

## VX-200XI Audio Input Module with Control Input

Audio Input Module with Control Input including low-cut and high-cut filter and gain control.



EN 54  
16

## VX-200XR / Q-VX-200XR Remote Microphone Input Module

Remote Microphone Input Module for RM-200X and RM-200XF. Q-VX-200XR with repeater circuit.

EN 54  
16

## VX-200SZ Impedance Detection Module

Audio signal output module with speaker line impedance detection. Detects speaker line short circuits, open circuits by comparing impedance and ground fault.



EN 54  
16

## VX-200SZ-2 Impedance Detection Module

Audio signal output module with speaker line impedance detection. Detects speaker line short circuits, open circuits by comparing impedance and ground fault. Since the module is equipped with 2 speaker outputs (A and B), broadcasts can be maintained even if one of the two outputs fails.

EN 54  
16

## VX-200SP Pilot Tone Detection Module

Audio signal output module with speaker line pilot tone detection. Detects speaker line short circuits, open circuits by monitoring for the presence of a pilot signal, and ground fault.



EN 54  
16

## VX-200SP-2 Pilot Tone Detection Module

Audio signal output module with speaker line pilot tone detection. Detects speaker line short circuits, open circuits by monitoring for the presence of a pilot signal with end of line module, and ground fault.

EN 54  
16

## VX-200SO Control Output Module

Used to increase the number of control outputs. It features 16 control outputs and is mounted in the VX-2000SF.



EN 54  
16

## VX-200SI Control Input Module

Used to increase the number of control inputs. It features 16 control inputs and is mounted in the VX-2000SF.

EN 54  
16

## VX-200SE Equaliser Card

A 9-band, 1-channel equaliser to be mounted on the circuit board of the VX-200SP/VX-200SP-2 Pilot Tone Detection module or VX-200SZ/VX-200SZ-2 Impedance Detection module.



EN 54  
16

## EV-200M Voice Announcement Board

To playback pre-recorded texts and sounds. The audio signals are stored on optional CompactFlash memory cards.



EN 54  
16

## Power Amplifiers

- VP-2064INCL (4 x 60 W)
- VP-2122INCL (2 x 120 W)
- VP-2241INCL (1 x 240 W)
- VP-2421INCL (1 x 420 W)

Power amplifiers with built-in Power amplifier Input Module VP-200VX. All models are also available without built-in Module.

## VP-200VX /VP-200VX-BGM Power Amplifier Input Module

For transmission of status and audio signal between amplifier and control module. VP-200VX-BGM features additional BGM input plus muting.



EN 54  
16



EN 54  
16

## VX-2000DS Emergency Power Supply

Supplies the DC power to each equipment in the VX-2000 system by connecting the VX-200PS Power Supply Unit. It keeps the battery unit that contains 2 x 12 V sealed lead batteries charged. When the DC power supply from the VX-200PS stops, the VX-2000DS is automatically switched to the backup battery.

## VX-200PS Power Supply Unit

2 DC output channels per unit. Use the VX-200PS in the number suited to the required total system power.



EN 54  
16



EN 54  
16

## VX-2000PF Power Supply Frame

Up to three VX-200PS units can be installed in the unit.

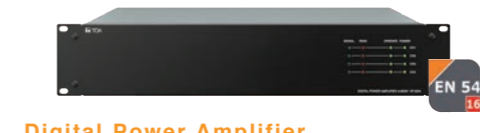

EN 54  
16

## Digital Power Amplifier

- VP-3154 (4 x 150 W)
- VP-3304 (4 x 300 W)
- VP-3504 (4 x 500 W)

The digital amplifiers are compact, lightweight and energy efficient. Each channel has an independent power source for enhanced reliability, and BGM input ports support BGM broadcasting.



EN 54  
16

## VX-3000DS Power Supply Manager

Supplies DC power to all VX-2000 system components. It combines two built-in power source units with a high-performance charger. If the primary power supply is cut off, the VX-3000DS switches automatically to auxiliary battery power.

## ACCESORIES

### RK-8VXA Relay card

Board with 8 relays for universal use, e.g. control of external devices, zone selection, 24V DC output for external equipment. Mounting on DIN rails.



### ATT-100VI Transformer board

For 100 V to Line level transformation with isolation of output against input. Mounting on DIN rails.



### RC-2144 Modem for Remote maintenance

For remote maintenance or transfer of system data. Fax and SMS messages are automatically generated. It is dial line and permanent line connection possible. The data transmission is analog (or on request: ISDN, DECT, GSM). Mounting on DIN rails.



### VX-RJA RJ-45 Connection board

For easy cable connection to RJ45, e.g. remote microphones, control inputs and outputs.



### IP-EN1-EB Indication panel

Indication panel for standard-compliant system message. LED indicators for status and error messages from the voice alarm system.



EN 54  
16

### NX-100 Network Audio Adapter

For transmitting audio signals in high sound quality as well as control and data signals over IP networks.



EN 54  
24

### Certified Loudspeakers

Certified loudspeakers specially designed for use in voice evacuation systems are available in various designs.

